



W orkshop

W idows

*A Survival & Support Guide –  
For Those That Didn't Attend The Life Changing  
Workshop*

L. Neil Thrussell  
Illustrations by Ruth Merkis-Hunt

**Text Copyright © September 2005 by L. Neil Thrussell**

Calgary, Alberta, Canada

**Illustration Copyright © September 2005 by Ruth Merkis-Hunt**

Ottawa, Ontario, Canada

**Cover Design by L. Neil Thrussell**

The text included in this publication has been created with the specific intention to be viewed on a computer screen (E-Book). So it has been formatted with larger font sizes - Times New Roman® 14 pt and Arial® 14 pt - to optimize viewing.

Published by Best U Can B Inc.

63 Martin Crossing Park NE

Calgary, Alberta T3J 3N7

<http://www.bestucanb.ca>

First printing September 2005

ISBN 0-9736704-2-8

All rights reserved. No part of this book may be reproduced nor transmitted in any form or by any means, electronic or mechanical, including photocopying, recording or by any storage or retrieval system, without written permission from Best U Can B Inc.

## Workshop Widows

The contents of this book are meant to entertain as well as provide you, the ‘Workshop Widow’ (spouse, life partner, roommate or friend who chose not to, or were unable to, attend the cataclysmic, life-altering workshop), with tools to survive - and perhaps capture some of - the incredible onslaught of energy and vitality that the participant of a truly life changing workshop (the ‘Workshop Warrior’) is bringing home.

*Note: I am using the term ‘Workshop Widows’ to include both genders. I like the way the words “Workshop Widows’ rolls off my tongue better than the way “Workshop Widowers’ does. I will be using the term ‘Workshop Warrior’ to describe the participant who attended the workshop.*

After hearing about and experiencing first-hand, the disturbance that can be caused to one’s family (just by the sheer exuberance of the workshop / seminar participant) when one member attends a workshop, I thought I should write a handbook to help out the ‘**Workshop Widows**’.

**A Life Changing Workshop is:**

An environment where a person is made to feel safe and valuable; a place where each person’s opinion matters; a process in which each person may come to realize what they truly need and to learn to understand their deeper feelings.

L. Neil Thrussell

*“It’s important that someone celebrate our existence... People are the only mirror we have to see ourselves in.”*

*Lois McMaster Bujold*

## Acknowledgements

I would like to acknowledge those people who guided me along in my journey to create Workshop Widows. First and foremost, my wife of twenty years, Tina, whose love and boundless energy never cease to amaze me. I love you lots! Thanks for your initial and final editing on 'Workshop Widows'.

To the wonderful people who took time out of their busy lives to provide me with guidance and support in writing of 'Workshop Warriors': Rick Martin; Jean Hudson; Jan Dixon; and Birgitte Michie; whom I also have the privilege to call friends. Thank you!

A big thank you goes out to Ricardo Fernandes Castelejo, whom I've never met. Ricardo allowed me to use his origami patterns in Workshop Widows.

I would also like to say a special thank you to the participants of the various workshops that Tina and I have facilitated in the last year and a half. Your participation and enthusiasm has provided me with a greater understanding of what happens when you turn 'Workshop Warriors' loose to their unsuspecting spouses / life partners. You have provided me with the inspiration to write this ebook... Thank You!

## Foreword

As a 'Workshop Widow' (married to one of those glassy-eyed, whirling dervishes himself), Neil Thrussell certainly has plenty of experience coping with the aftermath of a life-changing workshop. On many occasions he has witnessed me enthusiastically head out the door to attend a workshop, to return as a bundle of feverish energy bursting through the door several hours (or in some cases, several days) later... and he has patiently sat through the storm.

Neil has listened for hours to my excited ramblings after I have attended a life-changing workshop. He has persevered to understand the scope and impact of my '*aha's*', all the while managing to retain his sanity.

The sound advice he presents in this book comes from practical experience and his brilliant sense of humour, which has been a gift to us both through our twenty years of marriage.

Enjoy the pages that follow and delight in the joy of being a 'Workshop Widow'!

Tina Thrussell,  
President,  
Best U Can B Inc.

We must be the change  
we wish to see.

Mahatma Gandhi

Here's a stereotypical scenario that illustrates how I think the average 'Workshop Widow' finds out about the maelstrom that is about to descend upon them... *forever changing their life.*

You, the 'Workshop Widow' are comfortably sitting in your favorite chair. You have your beverage of choice in hand. The TV remote is in its proper location with a snack off to the side. The movie you are watching is in the last 10 minutes. You are putting the whole convoluted movie plot together when you hear the garage door open. You smile to yourself. "Perfect timing!" By the time the movie is over your workshop groupie will have brought their stuff in from the car and you'll be ready to hear all about the workshop. Then you can get back to the movies because you rented two of them. One movie for yourself and one for the both of you to watch together.

You hear the car door close. Then the back door smashes wide open. Things seem to explode throughout the house. The dog starts barking. Your partner starts screaming, "Honey, Honey, where are you?", frantically running from room to room trying to find you. Everyone knew your plans for the weekend were to sit in front of the TV... all weekend long. Foolishly, you try concentrate on the screen to figure out what's going on in the movie, so you'll know where to rewind it back to. After the third circuit upstairs your partner decides beyond a reasonable doubt that you are downstairs...

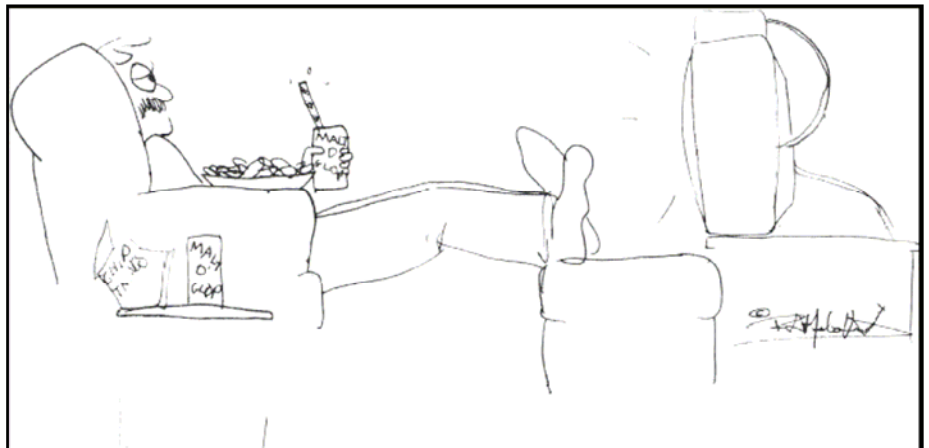

In your mind you're becoming a little afraid of what's coming bounding down the stairs. You hear the theme song from Jaws go through your mind "dudum, dudum, dudum"...

BAM! Before your very eyes a disheveled, glassy eyed, smiling (perma grin) tear-stained person bursts into the room, talking to you faster than the speed of sound. Well, it must be that fast because you can't figure out a word of what they have said besides.... "It was great..... Life Changing..... You have to do it..... If you loved me..... Life Changing..... Awesome..." All the while they're hugging you twenty more times than they have in the last two

months of your relationship. You're left just standing there, your mind reeling, incapable of processing any of this bombardment of information. You've never seen this person exude this much enthusiasm... for anything in their life! Your senses are overwhelmed.

*Your life will never be the same... ever! Accept that fact and your life will start to get easier from this moment on.*

*-L. Neil Thrussell*

## **Survival Tip 1**

Hug them. Share their enthusiasm. At the first appropriate moment, take a step back, look them in the eyes and say something like this, "Honey, I want to hear all about your experience. So let's make a cup of tea / coffee (*beverage of choice*) and sit down and you can tell me all about it."

(Note: You want to make something to drink. Why? To give your body and mind a few minutes to ramp up to their level of excitement and speed.)

So, take a few minutes, turn the TV off and put the answering machine on. Make your beverages of choice, then sit down and use your ACTIVE Listening Skills<sup>1</sup> and really listen. No, I mean **really** listen. Listen with your ears. Listen with your heart. Listen for the little meanings of what they are trying to say.

*Compassion and love are not mere luxuries. As the source of both inner and external peace, they are fundamental to the continued survival of our species.*

*-Dalai Lama, The Times (1999)*

Share in their joy, share their excitement. Let them revel in their happiness for as long as they are able to sustain it. They have just spent time in a very positive, caring and empowering place. They are on top of the world! They are filled with love, hope, happiness and dreams. What they really, really... really don't need is YOUR help to bring them crashing back down to the facts of every day life. That, unfortunately, will occur naturally soon enough. (I'll talk about this later on in the book, but for now it is just sufficient to say that after a 'Life Changing Workshop', sorting out the workings of life afterwards can be somewhat troublesome.)

---

<sup>1</sup> Make eye contact, provide visual and audible responses and carefully paraphrase their statements and ideas without interrupting. Techniques learnt in BestUCanB's - *Heard and Be Heard* workshop series. [www.bestucanb.ca](http://www.bestucanb.ca)



These new passionate dreams that the ‘Workshop Warrior’ comes home with are often about change. Change in their lives, what they want to do and what they don’t want to do. These changes in MOST cases aren’t about you, they are about how the ‘Workshop Warrior’ has to change / wants to change, to lead a more fulfilling life. In a lot of cases, it’s not because they are in a situation they hate, but in a situation where they want to be better. They’ve realized they want to be more than they already are.

e.g. “Honey, I’ve finally realized that I’m getting a little heavier than I would like. I’m going to have to start eating healthier. Will you help me out? Will you start to eat healthier with me?”

\*\*\*\*\*

You’ve now sat at the kitchen table for more than an hour. You’ve absorbed so much information, you’re not even sure what the movie is about any more.

When you hear, “I want us to sell everything and go live on ‘Bonin Island<sup>2</sup>’ and take up the art of Origami”, red flags raise in your mind. You’ve just bought your dream 56” inch surround sound TV with a 50,000-watt sub-woofer and a 7-satellite dish network. “I would also like us to take my mother with us”, is the next thing you hear. Without a second thought you bellow in a panicked tone that is intended to end all form of discussion, “Not in my life time!”

*The future belongs to those who believe in the beauty of their dreams.  
-Eleanor Roosevelt, US Diplomat and Reformer (1884 – 1962)*

## **Survival Tip 2**

Dreams are one of the most powerful driving forces in our lives. They are what give us purpose and they keep us moving forward. Dreams keep us growing. From our earliest childhood memories we all had dreams – you wanted to be a fireman / you wanted to be a doctor / you wanted to climb Mount Everest. As you blossomed into a teenager, your dreams may have changed slightly but you still had dreams. Maybe you wanted to play hockey and be the next Wayne Gretzky or Mario Lemieux or you were going to hop into your car and drive to California with some friends. Some of your dreams began to take shape and started to define your actions. You got up early in the morning to go to hockey practice / you made sure that you took the correct academic classes so you could enter university - working towards becoming a doctor.

---

<sup>2</sup> Small Japanese island in the Philippine Sea.

*Go confidently in the direction of your dreams. Live the life you have imagined.  
-Henry David Thoreau*

Our dreams and the dreams of our friends and loved ones are not meant to be taken lightly.

Thomas Edison would not have invented the carbon filament light bulb had he not been passionate and steadfastly determined about his dream. Thomas Edison tried nearly 10,000 experiments to get his light bulb to work correctly.

Unfortunately not all of us have Thomas Edison's determination so we can be very easily discouraged from pursuing our dreams after as little as one or two failures. Even worse, we can be discouraged from even **trying** to achieve our dreams by having our friends simply tell us, "it can't be done".

You must proceed with respect and caution when you are discussing anyone's dreams; especially the visions or dreams of the 'Workshop Warrior'. "Why?" you ask. Well quite likely you are the first person they have seen outside of the workshop since their life altering experience and your reaction will make a huge impact on them. It is quite possible that if you offer the first negative opinion about their dream since they took ownership of it at their recent workshop, you could hamper or even destroy their enthusiasm. So, listen with an open mind. Do not criticize. Let them explain fully their dreams and visions for the future. Let them fantasize about the future. Give them time to digest and understand what it is they truly desire. (Your job is to listen and support.)

*As human beings it is our job to nurture our loved one's dreams.  
-L. Neil Thrussell*

## Dreams Exercise

As a way to support and assist in making the dreams of the 'Workshop Warrior' - and your own dreams - become a reality, take a few moments together to write down your dreams. Then make a few notes on how you can and WILL support each other's dreams in the immediate future. (See Appendix A for a worksheet for this exercise)

<b>'Workshop Warrior's' Dreams</b>	<b>'Workshop Widow's' Ways to Support the Dream</b>
<i>Live on Bonin Island</i>	<i>Find out where Bonin Island is and how to get there</i>
<i>Art of Origami</i>	<i>Get book on Origami; buy paper</i>

Further on in the book we will come back to this exercise and elaborate on supporting each other's dreams with longer-term plans.

\*\*\*\*\*

Now your butt really hurts from sitting at the kitchen table, your bladder is going to burst and the energizer bunny sitting across from you is still in full wind about the merits of this awe inspiring workshop. Your mind is screaming! If you hear another word about the virtues of this great Inspirational Sage, you'll hunt down this Sage and force them to listen to 1000 non-stop hours of CSPAN<sup>3</sup>. You excuse yourself to go to the bathroom to get a few minutes reprieve. Without missing a beat and following three steps behind, comes the energizer bunny. You close the door behind you. Despite the solid oak door between you, you can still hear, "Fabulous" .... "We did this exercise, but I can't tell you what we did, in case you take the workshop".... You turn on the fan in the bathroom.



The excited little voice that has barraged your senses for the last hour and a half is no longer audible. The whirl of the fan has given you a temporary reprieve.

The door abruptly flies open, a smiling happy face pops in, "I'll go wash up now. We can talk more when I'm done". The door swings closed. You take a deep breath and begin to contemplate on whether or not you could comfortably sleep in the bathroom with the door locked! The whirl of the fan suddenly seems

---

<sup>3</sup> TV Cable Channel that broadcasts live Canadian and American Parliamentary Procedures

soothing. The quiet solitude of your weekend movie-fest seems a dream of the distant past.

*Change your thoughts and you change your world.*  
- Norman Vincent Peale (1898 – 1993)

### **Survival Tip 3**

This is the time to show restraint and patience... an incredible amount of patience. Even though you probably want to cover your ears like you did as a child and run around the house screaming, “I’m not listening. I can’t hear you”, don’t. Somehow, somewhere, find the strength and courage to continue to actively listen without judgment. (*When you master this task your relationship will forever be changed, for the better.*) When your ‘Workshop Warrior’ finally slows down and begins to think about their life-altering workshop in the days and weeks following, they will recall your reactions to the workshop and to them. They will reflect on coming home and downloading all their dreams and desires at 5000 megabits a second. They will remember you sitting patiently, listening without judgment, without ridicule. Your ‘Workshop Warrior’ will undoubtedly have a renewed sense of trust and value in you. Heck, you’ll even be proud of yourself!

This is the time to help gently flesh out their dreams. Go back and review **Appendix A**. Find out why they want to go to Bonin Island and take up the Art of Origami. Find out what dream or fantasy they will be fulfilling as they set out on this new path. They may initially be embarrassed or reluctant to tell you, but since you’ve been such a good listener and offered to support their dreams, the ‘Workshop Warrior’ will eventually tell you!

Thanks to the increased use of DVD’s, a lot of movies now offer you the opportunity to view alternative endings. So I’d like to offer you an alternative story which is also a very typical scenario of the ‘Workshop Warrior’ homecoming.

\*\*\*\*\*

You hear the car door close and the back door creaking open. You hear what sounds like a suitcase smashing into your new oak casing, then a second resounding crash that sounds like someone has walked into the doorframe. You pause the movie and slowly head up the stairs. You hear the closet doors crash open and things falling to the floor. You hear the suitcase scrape and then bounce off the wall... more things falling to the floor. You slowly come



around the corner. You are shocked to see the appalling condition of your 'Workshop Warrior'. They appear to have been taken out behind the proverbial barn and had the living poo kicked out of them. You look into their face and see that they are completely and utterly exhausted. They are barely able to utter a hello! They see you and smile. They resume dropping everything that they were carrying in and with Zombie-like movements they head towards the bathroom. You ask them, "So how was the workshop? Did you learn lots?" All you get is grunts and monosyllabic responses, "Yes. No. " As you head to the bathroom with your 'Workshop Warrior', you steal a quick look at the front entrance. It looks like a small bomb exploded there. The entrance is strewn with things everywhere...

The bathtub has been drawn. Your 'Workshop Warrior' is immersed and encased in bubbles. You continue with your questioning, "Did you recognize anyone from the last workshop? How was the presenter? What topics did you cover? Did you have fun? What was presented? What was the food like?" Their eyes begin to flutter and then roll to the back of their head. Frantically you make a heroic lunge and grab them before they submerge...

## Survival Tip 3a

Some 'Workshop Warriors' come home completely and utterly exhausted, to the extent that they almost seem catatonic; they appear to just be going through the motions of life. The reason for this is they were asked to stretch well beyond their normal realm of comfort. They have focused on topics and discovered feelings that they didn't even know existed.

They may have been asked to open up their hearts to complete strangers and listen to strangers without judgment and ridicule. e.g. discussion on dreams and goals

They may have been asked to conquer physical challenges. e.g. fire walking, rappelling down a cliff.

They may have experienced exercises in trust. e.g. standing blindfolded on a ladder and asked to just let go of the ladder and fall into the arms of a group of people below.

In short, they are temporarily overwhelmed and are incapable of processing another thought or feeling. They are on sensory overload. Quite possibly, the 'Workshop Warrior' has just discovered things about themselves that they did not like and they are trying to understand how to make changes for the better in their lives. Or they are just trying to come to grips with their newly found discovery.

They need time to unwind. They need time to sort out what they have learned and what is it they want out of life. How much time? That is very much dependant on the 'Workshop Warrior' and the issues that they are dealing with. As a considerate 'Workshop Widow', please give the 'Workshop Warrior' at least a few days to try to get back to a semblance of normalcy. Some 'Workshop Warriors' may need **more** than a few days to sort out their feelings so please be understanding of their needs.

This is a time when you, the 'Workshop Widow', need to possess an extraordinary amount of respect and patience. Give the 'Workshop Warrior' time and space. Don't press them for immediate answers. Instead take a few minutes and write down your question(s) or catalogue them in that huge storage and information retrieval system you possess called the human brain.

*Have patience with all things, but chiefly have patience with yourself. Do not lose courage in considering your own imperfections but instantly set about remedying them - every day begin the task anew. - Saint Francis de Sales*

Even though you didn't attend the life-changing workshop, just associating with your 'Workshop Warrior' will change your life. You can try to fight it, but change will be inevitable. Once a person catches a glimpse of their truest heart's desire, they will never, ever be truly satisfied until they have achieved it (or some form of it). If a dream is thwarted, squashed or delayed, it will still resurrect itself years later, possibly in counselling, or as a pent up frustrated emotion that explodes in an argument.

\*\*\*\*\*

You feel the sweat pour down your back. It's only lunchtime and it is already +35°C. The stench off the hot asphalt hangs in the air. The high humidity only adds to your already intense discomfort. You haven't slept well for the last couple of nights. Your 'Workshop Warrior' was still incessantly talking about going to the Bonin Island and taking up Origami. It has been a very tiring three nights. You thought they would have forgotten about this wild notion by now! You had even secretly hoped that when you brought the book on the Bonin Islands home on Monday night that would be the end of it. But NO! That just seemed to intensify their longing to visit this mystical land.

You make another pass over the sweltering hot asphalt with your 20-ton packer. The rising heat off the asphalt seems to add another 10 degrees to the already intolerable heat. You see your foreman wave you over; it's time for lunch. You feel the skin on your back peel off of the hot sticky vinyl seat of the packer. You grab your lunch bucket and head off to have lunch with the crew. The temperature seems impossibly hotter on the ground as you walk towards the shaded area where the rest of the crew sits. You walk by the water jug and quickly guzzle down three glasses of ice-cold water. That doesn't really seem to quench your thirst. So you pour two glasses over your head. That seems to give you a temporary reprieve from the heat. As you walk over and sit down, the crew asks you, "so you still moving to Bonin Island?" One even hands you a folded paper swan and says "my son made this. I thought you might want to see what you could build with your new career!" You have no idea why you told them of your 'Workshop Warrior's' dreams, but you did and they now seem intent on reminding you of how impossible those dreams seem.

You open your lunchbox and instead of the familiar sandwich containers you see a couple large containers that you don't recognize. You also see a folded piece of paper in your lunch bucket. Thinking it was a bill or receipt of some kind, you absent-mindedly unfold the paper! There you see three simple symbols, "I♥U". You stare at it open mouthed for the briefest of seconds, before



your brain registers and reacts to the immanent danger of reading this type of note in the presence of this pack of red necked wolves called your co-workers. The alpha male of the pack senses your discomfort and moves in quickly for the kill. He strikes without warning and grabs the note from your hand, then beats a hasty retreat out of your way. He reads your note. Just by the sheer childish glee in his eyes, you know every paving crew east of the Rockies will now know some embellishment about your note.

In the small recesses of your mind you are actually touched by the note. The rest of your brain is screaming at the top of its small internal voice, "what the heck was my 'Workshop Warrior' thinking?" The day is not going well for you. The temperature is making you miserable and now the note. You breathe a deep sigh. Well at least you're not still out baking in the sun.

You open the first container in your lunchbox. Your jaw drops as you stare at the contents in absolute horror and disbelief. You begin to hyper ventilate – in all the years you've been together, this is the craziest thing your 'Workshop Warrior' has ever done to you. This is even crazier than going to Bonin Island! You look back into your lunch bucket, and stare with astonishment and disgust at the tofu casserole in front of you.

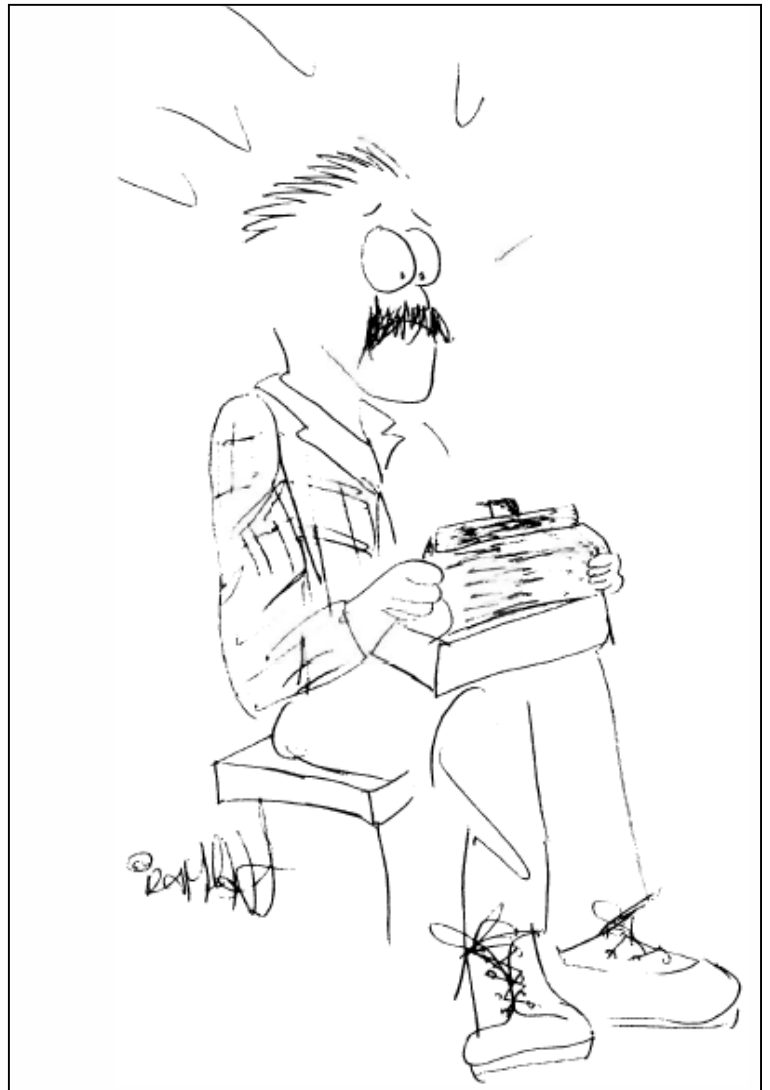

*So many of our dreams at first seem impossible, then they seem improbable, and then when we summon the will, they soon become inevitable.*

*- Christopher Reeve*



## Survival Tip 4

Arrange for you and the ‘Workshop Warrior’ to have a quiet undisturbed conversation. That means no TV, no kids, no phones, no outside influences, just the two of you. In your conversation, revisit the Dreams listed in ‘Appendix A’ and ask the question without emotional attachment, “Is this still your dream?” Ask this not with the intent of talking them out of it, but rather as an opportunity to have the dream clarified now that the ‘Workshop Warrior’ has had time to think outside of the highly charged workshop. Now is the time to be further inspired or to realize that they still have dreams, but a slightly different version than what they shared with you previously. This is the ideal time for a review of the facts.

After your discussion, you’ll have a clearer understanding of the dream(s). Now both of you get a pen and answer this question separately **“What do I need to do to make this happen?”**

*(See Appendix B for a worksheet for this exercise)*

<i>‘Workshop Warrior’s’ Dreams</i>	<i>What do I need to do to make this happen?</i>
Live on Bonin Island	Quit Job
	Sell House
	Sell Boat
	Buy Plane Ticket

Since this isn’t intended to be the final list but rather a working list, agree to a set a time limit to do this exercise. Let’s say 20 minutes maximum.

Now swap lists and read each other’s “What do I need to do to make this happen?” list (Appendix B).

\*\*\*\*\*

You’re sitting all comfy in your favorite reclining chair, seat tilted all the way back. Your feet are nicely elevated, your favorite beverage is on the table right beside you. Your ‘Workshop Warrior’ hands you their list of “What do I need to do to make this happen?”. (Appendix B) -Your feet slam down. You jump out of your chair, spewing your favorite beverage all across the room. “What do you mean sell my Star Wars action figure collection? I have the original collectors edition of

Darth Vader still in the box. I stood in line for hours at the toy store<sup>4</sup> to get him”.

*No act of kindness, no matter how small, is ever wasted.*

*- Aesoph (620 BC – 560 BC)*

After you’ve looked over each other’s list and compared whose list was longer or whose list was more complete, you’ll want take a break. Go for a walk, plug in the kettle, or make a pot of coffee. Take a bit of time for a mental health break from the exercise.

Now you’ve attended to your biological needs and you’ve got your steaming hot beverage beside you, look at your “What do I need to do to make this happen?” lists (Appendix B) and combine them. Create a master list. You can add to this list in the future as you discover things you may not have thought about now. E.g. getting the dog vaccinated for the trip.

With as little emotional attachment as you can humanly muster, dig deep into the caring, nurturing side of you. Discuss each one of the items on your master list.

As you go through each of the items listed, you may find you’re having difficulties releasing emotional attachment to a particular item or idea. If this is the case, skip over it and go on to the next item on the list. Come back to the unresolved item later. It may take hours, days, weeks or even months to resolve the issue. Be persistent; dreams are always worthwhile pursuing.

(See Appendix C for a worksheet for this exercise)

<b>“What do I need to do to make this happen?”</b>	
<b>Sell House</b>	
<b>What Emotional Attachment do I have to this item?</b>	<b>What do I need to do to ease my emotional attachment to this item?</b>
<b>It has been in the family for 100 years.</b>	<b>1) Sell house to family member 2) Rent it out - have money deposited in account on Bonin Island</b>

<sup>4</sup> Workshop Widow actually meant to say, “I stood in line for hours at the **action figure** store”, but in his emotional distraught state he said, “**toy store**”

For the purpose of this story, I've concentrated solely on the dreams of the 'Workshop Warrior', but the dreams of the 'Workshop Widow' are of equal importance. Therefore ensure the discussion is a two way street. Make sure both sets of dreams are mapped out equally.

\*\*\*\*\*

Your fingers are aching. You never imagined in a million years (no make that 10 million years) that folding a bunch of paper could be so darn difficult. If it weren't for the calluses on your hands from hard manual labor your hands would be as shredded with paper cuts as your 'Workshop Warrior's'. (Life lesson - you no longer laugh at the damage a paper cut does, because you know how much it hurts)

You've been on the island for almost three glorious weeks now. The locals are friendly enough; they've even quit commenting on the number of pieces of paper you ruin for each successful one you fold. They've been kinder since they found you a task that you were exceptionally good at. With the expansion of the local Zen Garden, someone had to shovel all the rocks into the new space. It was a win – win situation. Your absence from the folding table meant that they were saving paper (actually a lot of paper) and your cramped and paper cut hands have had a chance to heal.

You're really going to miss this place. Your vacation is almost over.



## Survival Tip 5

**Don't be afraid to try new things.** If you're not sure how you're going to like something, don't jump in with both feet. Try it out for a couple weeks. Take a course. Read the book. Take a few small 'baby' steps before you make a huge life change. Test it out until you know you're ready to live with your decision.

I worked with a gentleman whose retirement dream was to buy a fifth wheel travel trailer, live in it and travel around North America. He and his wife borrowed a truck and trailer from a family member and went for a one-month vacation. It was a pre-retirement test. He's now retired to a small town. She does pottery and he does woodwork. The month long trip saved them a lot of money and most likely their 30-year marriage, as well...

Remember, people can and do change over time. What is right for you today, may not be right for you tomorrow. Understanding this will help you learn to accept change.

*Change your thoughts and you change the world.*

*- Norman Vincent Peale (1898-1993)*

If there would be one lesson to be learnt from this book, that lesson would be patience. Have patience to allow time for the lessons that will affect change to take hold. Have patience for the 'Workshop Warrior's' exuberance. Show compassion for the 'Workshop Warrior' and their newly found passion and desire to achieve their dreams. Also have patience for your own actions or reactions. Getting annoyed because you don't immediately understand where all these dreams are coming from or even where they are leading you will get you nowhere. Give the dreams time to percolate, time to expand. With patience and a plan, your dreams will come to life.



Dream big and dream in full color! And remember, not all dreams come to fruition on their first attempt.

*We must be the change we wish to see.*

*-Mahatma Gandhi*

## Appendix A

<b>‘Workshop Warrior’s’ Dreams</b>	<b>‘Workshop Widow’s’ Ways to Support the Dream</b>



## Appendix C

<b>“What do I need to do to make this happen?”</b>	
<b>What Emotional Attachment do I have to this item?</b>	<b>What do I need to do to ease my emotional attachment to this item?</b>

<b>“What do I need to do to make this happen?”</b>	
<b>What Emotional Attachment do I have to this item?</b>	<b>What do I need to do to ease my emotional attachment to this item?</b>

**Origami Sample** (see <http://www.origami.com/> for additional diagrams)

**BABY ELEPHANT WITH THREE LEGS**

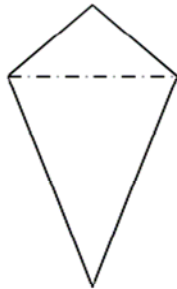

1. Start with a bird base. Sink.



2. Reverse-folds.

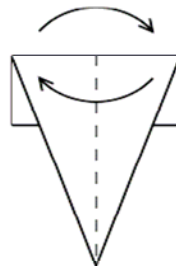

3. Fold one layer to the left unfolding step 2. Repeat behind. Repeat step 2.

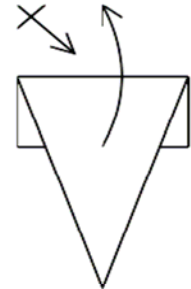

4. Pull up. Repeat behind.

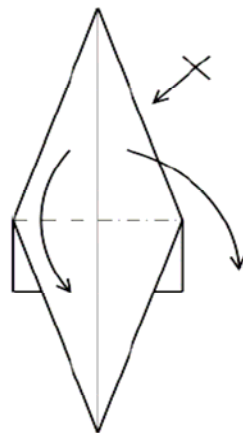

5. Pull down while opening the flap on the right. Repeat behind.

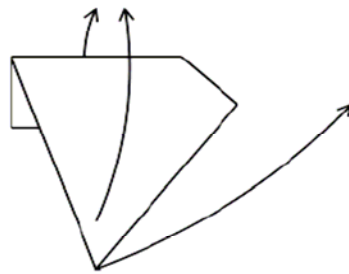

6. Open.

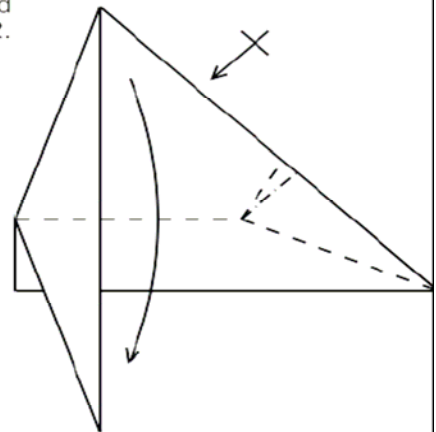

7. Fold down. A new crease will appear. Repeat behind.

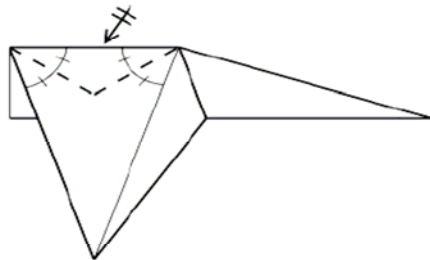

8. Crease bisectors. Repeat behind.

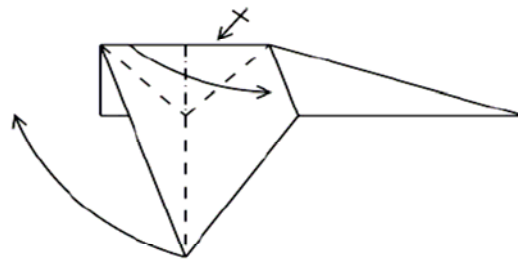

9. Fold to the right while pulling the inner layer up.



# BABY ELEPHANT WITH THREE LEGS

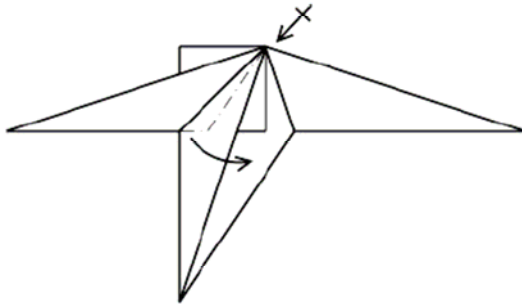

10.  
Gently pull the leg back using the creases made in step 8. A new crease will be necessary in the back leg.  
Repeat behind.

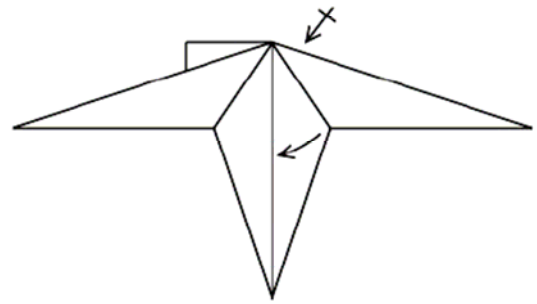

11.  
Inside reverse-fold to perform the leg.  
Repeat behind.

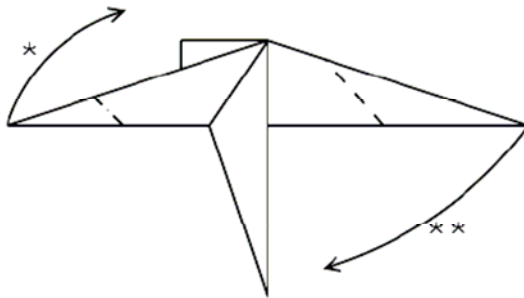

12.  
\* Inside reverse-fold.  
\*\* Outside reverse-fold.

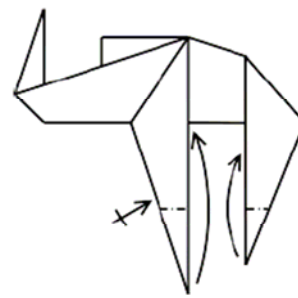

13.  
Inside reverse-fold the three legs.

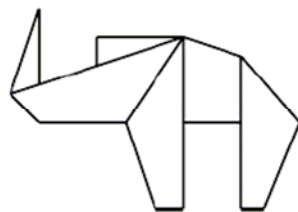

14.  
Done!  
Baby elephant with three legs.

## **Forthcoming E-Books From Best U Can B Inc.**

**By L. Neil Thrussell**

### **Non Fiction**

*To be released September 2006*

**If You Want To See a Man Cry Just Poke Him In The Eye**

ISBN Forthcoming

### **Fiction**

*To be released October 2005*

**Friendship, Honor and Valour: E-book Version**

ISBN 0-9736704-9-5

*To be released January 2006*

**Friendship, Honor and Revenge: E-book Version**

ISBN 0-9739042-1-6

*To be released July 2006*

**Friendship, Honor and Justice: E-book Version**

ISBN 0-9739042-3-2

---

**By Tina H. Thrussell**

### **Non-Fiction**

*To be released September 2005*

**Believe In Yourself - You Are Awesome (Journaling with Intention):**

**21 Day: E-book Version**

ISBN 0-9736704-3-6

*To be released March 2006*

**The Write Way to Love Your Life (Journaling with Intention)**

ISBN 0-9736704-5-2

*To be released September 2006*

**Raising Vibrations by Journaling with Intention**

ISBN 0-9736704-7-9